

Entanglement in an $SU(n)$ valence-bond-solid state

This article has been downloaded from IOPscience. Please scroll down to see the full text article.

2008 J. Phys. A: Math. Theor. 41 135304

(<http://iopscience.iop.org/1751-8121/41/13/135304>)

View [the table of contents for this issue](#), or go to the [journal homepage](#) for more

Download details:

IP Address: 171.66.16.147

The article was downloaded on 03/06/2010 at 06:38

Please note that [terms and conditions apply](#).

Entanglement in an $SU(n)$ valence-bond-solid state

Hosho Katsura¹, Takaaki Hirano¹ and Vladimir E Korepin²

¹ Department of Applied Physics, University of Tokyo, 7-3-1, Hongo, Bunkyo-ku, Tokyo 113-8656, Japan

² C.N. Yang Institute for Theoretical Physics, State University of New York at Stony Brook, Stony Brook, NY 11794-3840, USA

E-mail: katsura@appi.t.u-tokyo.ac.jp, hirano@pothos.t.u-tokyo.ac.jp and korepin@insti.physics.sunysb.edu

Received 29 November 2007, in final form 18 February 2008

Published 14 March 2008

Online at stacks.iop.org/JPhysA/41/135304

Abstract

We investigate entanglement properties in the ground state of the open/periodic $SU(n)$ generalized valence-bond-solid state consisting of representations of $SU(n)$. We obtain exact expressions for the reduced density matrix of a block of contiguous spins and explicitly evaluate the von Neumann and the Rényi entropies. We discover that the Rényi entropy is independent of the parameter α in the limit of large block sizes and its value $2 \log n$ coincides with that of von Neumann entropy. We also find the direct relation between the reduced density matrix of the subsystem and edge states for the corresponding open boundary system.

PACS numbers: 75.10.Pq, 03.65.Ud, 03.67.Mn, 05.70.Jk

1. Introduction

There is considerable current interest in quantifying entanglement in various quantum many-body systems. Entanglement in spin chains, correlated electrons, interacting bosons and other models was studied in detail [1–20]. Entanglement is a resource for quantum computation, it shows how much correlation we can use to control quantum devices [21, 22]. There are several different measures of entanglement. The most famous is the von Neumann (entanglement) entropy of a subsystem [21]. This measure has recently been used to detect quantum phase transitions and topological/quantum order [23, 24] in strongly correlated systems. We can also use the Rényi entropy to quantify the entanglement. The Rényi entropy was first proposed in information theory [25]. The von Neumann entropy $S(\rho_A)$ and the Rényi entropy $S_\alpha(\rho_A)$

are defined as follows:

$$S(\rho_A) = -\text{Tr}(\rho_A \log \rho_A) \quad (1)$$

$$S_\alpha(\rho_A) = \frac{1}{1-\alpha} \log \text{Tr}(\rho_A^\alpha), \quad \alpha \neq 1 \quad \text{and} \quad \alpha > 0. \quad (2)$$

Here ρ_A is the reduced density matrix of subsystem A and the power α is an arbitrary parameter. The Rényi entropy characterizes the mixed state much better: if we know the Rényi entropy at any α we know all eigenvalues of the density matrix.

Studying entanglement also helps us to understand the physics of quantum spin systems [1, 2]. The model introduced by Affleck, Kennedy, Lieb and Tasaki (AKLT model) [26, 27] plays a very important role in condensed matter physics. The exact ground state of this model is known as the valence-bond-solid (VBS) state. In 1983, Haldane [28] conjectured that the antiferromagnetic Heisenberg Hamiltonian describing half-odd-integer spins is gapless, but for integer spins it has a gap. The AKLT model agrees with this conjecture and enables us to understand the ground-state properties of gapped spin chains in a unified fashion. The construction of the AKLT-type model is not restricted to one dimension. In fact, the AKLT model was formulated on an arbitrary graph and an integration over classical spins was used for the evaluation of correlation functions in the VBS ground state [29]. The VBS state has attracted revived interest from the viewpoint of quantum information theory. An implementation of the AKLT model in optical lattices was proposed recently [30], and the use of the AKLT model for *universal quantum computation* was discussed in [31]. The VBS state is also closely related to the Laughlin wavefunction [32] and to the fractional quantum Hall effect [33]. Entanglement in $S = 1$ AKLT model was first considered in [34]. Then the results were generalized to the arbitrary integer spin case in [35, 36]. An interesting generalization of the AKLT model to the $SU(n)$ version was constructed in [37, 38].

In this paper we study entanglement in the $SU(n)$ version of the AKLT model. We consider entanglement of a block of spins with the rest of the ground state. We evaluate the von Neumann and the Rényi entropies of the block. We first confirm that the von Neumann entropy of a large block of spins reaches saturation. This is a partial proof of the conjecture proposed by Vidal *et al* [3]. In the $SU(2)$ AKLT and the XY spin chains, this conjecture has already been proved and the limiting entropy of the large block of spins was explicitly calculated [6, 34, 35, 39–41]. We find the essential simplification in the limit of large block sizes. In this limit, we discovered that the Rényi entropy is independent of α , actually it coincides with the value of von Neumann entropy $2 \ln n$. This means that the density matrix of the block is proportional to the identity matrix of dimension n^2 . It is different from the XY spin chain, where the density matrix of the large block is infinite dimensional and eigenvalues are different (see [42]). We also explore the connection between the reduced density matrix of the subsystem and degenerate ground states for the corresponding open boundary system.

The paper is organized as follows. In the following section, we will study entanglement in the ground state of the $SU(n)$ AKLT model with boundary spins. This section is the main part of this paper. The von Neumann entropy and the Rényi entropy will be evaluated for the block of neighboring spins. We will also discuss the direct relation between the reduced density matrix for the block and the degenerate ground states of the AKLT model with an open boundary condition. In the third section, we will investigate entanglement in the ground state of the $SU(n)$ AKLT model with a periodic boundary condition. In this section, we will obtain the explicit form of the reduced density matrix. The finite-size effect of the von Neumann and the Rényi entropies will be studied. The last section will be devoted to summary and discussions.

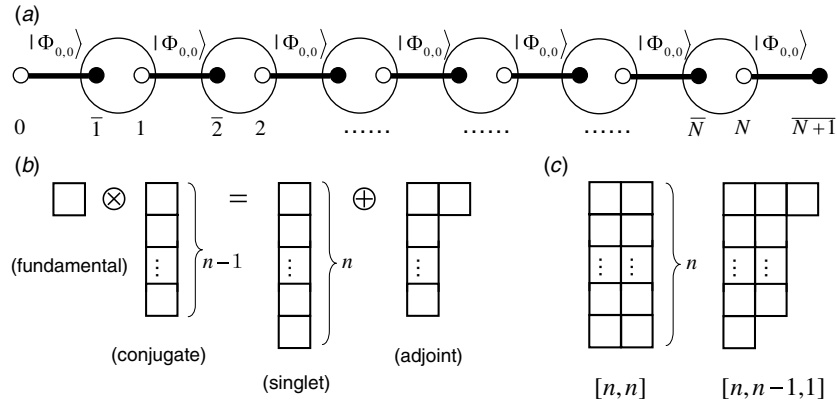

Figure 1. (a) Construction of the $SU(n)$ VBS state. White and black dots represent the $SU(n)$ fundamental and its conjugate representations, respectively. A dimer corresponds to the singlet state $|\Phi_{0,0}\rangle$ and a circle denotes the projection onto the adjoint representation. (b) The decomposition rule for the tensor product of $\square \otimes \square$. (c) Young tableaux corresponding to $[n, n]$ and $[n, n - 1, 1]$

2. The $SU(n)$ VBS state with boundary spins

2.1. Construction of the $SU(n)$ VBS state

In this section, we consider the $SU(n)$ VBS state with boundary spins and calculate the von Neumann entropy (entanglement entropy) and the Rényi entropy of a block of contiguous spins. What we mean by ‘spin’ in our system is an adjoint representation of $SU(n)$. We shall first construct an $SU(n)$ VBS state which consists of N adjoint representations of $SU(n)$ in the bulk and fundamental and conjugate representations of $SU(n)$ on the boundary. First, we prepare sites k ($k = 0, 1, \dots, N$) and \bar{k} ($k = 1, 2, \dots, N + 1$) and arrange $SU(n)$ singlets consisting of a fundamental (\square) and its conjugate ($\bar{\square}$) representations as shown in figure 1(a) [43]. We assign $|j\rangle$ ($j = 0, 1, 2, \dots, n - 1$) to the fundamental representation, while $|\bar{j}\rangle$ ($j = 0, 1, 2, \dots, n - 1$) to the conjugate representation. $|\bar{j}\rangle$ can be represented by the tensor product of $(n - 1)|j\rangle$ ’s as

$$|\bar{j}\rangle \equiv \frac{1}{\sqrt{(n-1)!}} \sum_{\alpha_2, \dots, \alpha_n} \epsilon^{j\alpha_2, \dots, \alpha_n} |\alpha_2, \dots, \alpha_n\rangle, \tag{3}$$

where $\epsilon^{j\alpha_2, \dots, \alpha_n}$ is a totally antisymmetric tensor of rank n . Using $|j\rangle$ and $|\bar{j}\rangle$, an $SU(n)$ singlet state $|\Phi_{0,0}\rangle$ can be represented as a maximally entangled state,

$$|\Phi_{0,0}\rangle = \frac{1}{\sqrt{n}} \sum_{j=0}^{n-1} |j\rangle |\bar{j}\rangle. \tag{4}$$

The above relation can be easily confirmed by inserting the resolution of the identity $1 = \sum_{j=0}^{n-1} |j\rangle \langle j|$ and substituting equation (3). Next, we prepare the adjoint representation of $SU(n)$ by projecting the tensor product $\square \otimes \bar{\square}$ onto an $(n^2 - 1)$ -dimensional subspace. This procedure corresponds to circles in figure 1(a). In figure 1(b), we visualize the decomposition rule $\square \otimes \bar{\square} = (\text{singlet}) \oplus (\text{adjoint})$. Then we obtain the $SU(n)$ adjoint representation at each

composite site (k, \bar{k}) . Henceforth we shall call this composite site k . Finally, we can represent the $SU(n)$ generalized VBS state as

$$|G\rangle = \left(\otimes_{k=1}^N P_{k\bar{k}}\right) |\Phi_{0,0}\rangle_{0\bar{1}} |\Phi_{0,0}\rangle_{1\bar{2}} \cdots |\Phi_{0,0}\rangle_{N\bar{N+1}}, \quad (5)$$

where $P_{k\bar{k}}$ is a projection operator onto an adjoint representation of $SU(n)$.

Let us now consider the Hamiltonian whose ground state is the above state we have constructed. The Hamiltonian can be constructed along the same line as the AKLT model,

$$H = \sum_{k=1}^{N-1} H_k + \pi_{0,1} + \pi_{N,N+1}, \quad H_k = \sum_Y a_Y P_{k,k+1}^Y, \quad (6)$$

where Y is a Young tableau which is neither $[n, n]$ nor $[n, n - 1, 1]$. Here we have assigned $[\kappa_1, \dots, \kappa_{\lambda_1}]$ to the Young tableau Y , where κ_j is the number of boxes in the j th column and λ_1 is the number of boxes in the first row. $P_{k,k+1}^Y$ is a projection operator which projects (adjoint) \otimes (adjoint) onto a representation characterized by Y and the coefficient a_Y can be an arbitrary positive number. The reason why $[n, n]$ and $[n, n - 1, 1]$ are excluded from the sum is the following. Since \square at site k and $\bar{\square}$ at site $k + 1$ have already formed a singlet in the ground state (5), the possible representations obtained from the decomposition of (adjoint) \otimes (adjoint) are restricted to $[n, n]$ and $[n, n - 1, 1]$ (graphically shown in figure 1(c)). $\pi_{0,1}$ and $\pi_{N,N+1}$ are boundary terms which assure the uniqueness of the ground state of this Hamiltonian. $\pi_{0,1}$ and $\pi_{N,N+1}$ can be written in terms of the projection operators acting on the tensor products (fundamental) \otimes (adjoint) and (conjugate) \otimes (adjoint), respectively. By construction, the $SU(n)$ VBS state (5) is a zero-energy ground state of this Hamiltonian. We should note here that another construction of Hamiltonian by Greiter and Rachel [38] is similar but slightly different from ours.

2.2. Reduced density matrix and von Neumann and Rényi entropies

Next, we consider the reduced density matrices of subsystems of the ground state $|G\rangle$. To calculate the reduced density matrix, it is more convenient to recast the chain of singlets $|\Phi_{0,0}\rangle_{0\bar{1}} |\Phi_{0,0}\rangle_{1\bar{2}} \cdots |\Phi_{0,0}\rangle_{N\bar{N+1}}$ in equation (5) in a different form. Let us first consider a chain of two singlets $|\Phi_{0,0}\rangle_{0\bar{1}} |\Phi_{0,0}\rangle_{1\bar{2}}$. We can rewrite this product state as

$$|\Phi_{0,0}\rangle_{0\bar{1}} |\Phi_{0,0}\rangle_{1\bar{2}} = \frac{1}{n} \sum_{l=0}^{n-1} \sum_{m=0}^{n-1} |\Phi_{l,m}\rangle_{0\bar{2}} |\Phi_{l,-m}\rangle_{\bar{1}1}, \quad (7)$$

where $|\Phi_{m,n}\rangle$ is a basis of the maximally entangled state defined by

$$|\Phi_{l,m}\rangle = (U_{l,m} \otimes I) |\Phi_{0,0}\rangle. \quad (8)$$

Here I is an n -dimensional identity matrix and $U_{l,m} = X^l Z^m$ ($m, n = 0, 1, \dots, n - 1$) are generalized Pauli matrices, where the unitary operators X and Z act on $|j\rangle$ as $X|j\rangle = |j + 1 \pmod{n}\rangle$ and $Z|j\rangle = \omega^j |j\rangle$ with $\omega = e^{2\pi i/n}$, respectively. One can easily show the relation (7) by using the fact that $|\Phi_{0,0}\rangle$ is invariant under the action of $(U_{l,m} \otimes U_{l,-m})$ [44]. This procedure can be regarded as a multi-dimensional generalization of entanglement swapping. Repeatedly using the relation (7), we can generalize in a straightforward way to a chain of singlet states,

$$\begin{aligned} |\Phi_{0,0}\rangle_{0\bar{1}} |\Phi_{0,0}\rangle_{1\bar{2}} \cdots |\Phi_{0,0}\rangle_{N\bar{N+1}} &= \frac{1}{n^N} \sum_{(l_1, m_1)} \cdots \sum_{(l_N, m_N)} |\Phi_{l_1, -m_1}\rangle_{\bar{1}1} \cdots |\Phi_{l_N, -m_N}\rangle_{\bar{N}N} \\ &\times (U_{l_1, m_1} \cdots U_{l_N, m_N} \otimes I) |\Phi_{0,0}\rangle_{0\bar{N+1}}, \end{aligned} \quad (9)$$

where (l_k, m_k) ($k = 1, 2, \dots, N$) runs from $(0,0)$ to $(n-1, n-1)$. To obtain the ground state $|G\rangle$ from (9), we have to make a projection onto the subspace of adjoint representation at each site k . Since the decomposition rule $\square \otimes \bar{\square} = (\text{singlet}) \oplus (\text{adjoint})$ and the fact that $|\Phi_{0,0}\rangle$ is an $SU(n)$ singlet, the vector space of the adjoint representation is spanned by $|\Phi_{l,-m}\rangle$ ($(l, m) \neq (0, 0)$). Then the only thing to do is to omit the summation over $(l_k, m_k) = (0, 0)$ in equation (9). The $SU(n)$ generalized VBS state can be rewritten as

$$|G\rangle = \frac{1}{(n^2 - 1)^{N/2}} \sum_{\substack{(l_1, m_1) \\ \neq (0,0)}} \cdots \sum_{\substack{(l_N, m_N) \\ \neq (0,0)}} |\Phi_{l_1, -m_1}\rangle_{\bar{1}1} \cdots |\Phi_{l_N, -m_N}\rangle_{\bar{N}N} (U_{l_1, m_1} \cdots U_{l_N, m_N} \otimes I) |\Phi_{0,0}\rangle_{0\bar{N}+1}, \quad (10)$$

where we have already normalized $|G\rangle$ by the factor $1/(n^2 - 1)^{N/2}$.

Let us now consider the reduced density matrix of a block of contiguous spins of length L . We first suppose that the block starts from site k and stretches up to $k + L - 1$, where $k \geq 1$ and $k + L - 1 \leq N$. The reduced density matrix is obtained by taking the trace over the sites $j = 0, 1, \dots, k - 1$ and $j = k + L, \dots, N, \bar{N} + 1$ as

$$\begin{aligned} \rho_L &= \text{Tr}_{1, \dots, k-1, k+L, \dots, N, 0, \bar{N}+1} |G\rangle \langle G| \\ &= \frac{1}{(n^2 - 1)^N} \sum_{\substack{(l_1, m_1) \\ \neq (0,0)}} \cdots \sum_{\substack{(l_{k-1}, m_{k-1}) \\ \neq (0,0)}} \sum_{\substack{(l_{k+L}, m_{k+L}) \\ \neq (0,0)}} \\ &\quad \cdots \sum_{\substack{(l_N, m_N) \\ \neq (0,0)}} \sum_{\substack{(l_k, m_k) \\ \neq (0,0)}} \sum_{\substack{(l'_k, m'_k) \\ \neq (0,0)}} \cdots \sum_{\substack{(l_{L+k-1}, m_{L+k-1}) \\ \neq (0,0)}} \sum_{\substack{(l'_{L+k-1}, m'_{L+k-1}) \\ \neq (0,0)}} \\ &\quad \times |\Phi_{l_k, -m_k}\rangle_{\bar{k}k} \langle \Phi_{l'_k, -m'_k}| \cdots |\Phi_{l_{L+k-1}, -m_{L+k-1}}\rangle_{\overline{L+k-1}L+k-1} \langle \Phi_{l'_{L+k-1}, -m'_{L+k-1}}| \\ &\quad \times \text{Tr}_{0, \bar{N}+1} (U_1 V U_2 \otimes I) |\Phi_{0,0}\rangle_{0\bar{N}+1} \langle \Phi_{0,0}| (U_1 V' U_2 \otimes I)^\dagger, \end{aligned} \quad (11)$$

where $U_1 = U_{l_1, m_1} \cdots U_{l_{k-1}, m_{k-1}}$, $U_2 = U_{l_{L+k}, m_{L+k}} \cdots U_{l_N, m_N}$, $V = U_{l_k, m_k} \cdots U_{l_{L+k-1}, m_{L+k-1}}$ and $V' = U'_{l'_k, m'_k} \cdots U'_{l'_{L+k-1}, m'_{L+k-1}}$. To rewrite equation (11), we use the following property of $|\Phi_{0,0}\rangle$:

$$(S \otimes T) |\Phi_{0,0}\rangle = (S T^t \otimes I) |\Phi_{0,0}\rangle = (I \otimes T S^t) |\Phi_{0,0}\rangle, \quad (12)$$

where S and T are n -dimensional unitary operators acting on $|j\rangle$ and $|\bar{j}\rangle$, respectively, and the superscript t denotes the matrix transposition. Using this property and the cyclic property of the trace, we can simplify the last part of equation (11) as

$$\begin{aligned} &\text{Tr}_{0, \bar{N}+1} (U_1 V U_2 \otimes I) |\Phi_{0,0}\rangle_{0\bar{N}+1} \langle \Phi_{0,0}| (U_1 V' U_2 \otimes I)^\dagger \\ &= \text{Tr}_{0, \bar{N}+1} (U_1 \otimes I) (V \otimes I) (U_2 \otimes I) |\Phi_{0,0}\rangle_{0\bar{N}+1} \langle \Phi_{0,0}| (U_2 \otimes I)^\dagger (V' \otimes I)^\dagger (U_1 \otimes I)^\dagger \\ &= \text{Tr}_{0, \bar{N}+1} (V \otimes I) (I \otimes U_2^\dagger) |\Phi_{0,0}\rangle_{0\bar{N}+1} \langle \Phi_{0,0}| (I \otimes U_2^\dagger)^\dagger (V' \otimes I)^\dagger \\ &= \text{Tr}_{0, \bar{N}+1} (I \otimes U_2^\dagger) (V \otimes I) |\Phi_{0,0}\rangle_{0\bar{N}+1} \langle \Phi_{0,0}| (V' \otimes I)^\dagger (I \otimes U_2^\dagger)^\dagger \\ &= \text{Tr}_{0, \bar{N}+1} (V \otimes I) |\Phi_{0,0}\rangle_{0\bar{N}+1} \langle \Phi_{0,0}| (V' \otimes I)^\dagger. \end{aligned} \quad (13)$$

Since (13) does not depend on $(l_1, m_1), \dots, (l_{k-1}, m_{k-1})$ and $(l_{k+L}, m_{k+L}), \dots, (l_N, m_N)$, we can rewrite equation (11) as

$$\begin{aligned} \rho_L &= \frac{1}{(n^2 - 1)^L} \sum_{\substack{(l_k, m_k) \\ \neq (0,0)}} \sum_{\substack{(l'_k, m'_k) \\ \neq (0,0)}} \cdots \sum_{\substack{(l_{L+k-1}, m_{L+k-1}) \\ \neq (0,0)}} \sum_{\substack{(l'_{L+k-1}, m'_{L+k-1}) \\ \neq (0,0)}} |\Phi_{l_k, -m_k}\rangle_{\bar{k}k} \langle \Phi_{l'_k, -m'_k}| \\ &\quad \cdots |\Phi_{l_{L+k-1}, -m_{L+k-1}}\rangle_{\overline{L+k-1}L+k-1} \langle \Phi_{l'_{L+k-1}, -m'_{L+k-1}}| \text{Tr}_{0, \bar{N}+1} (V \otimes I) |\Phi_{0,0}\rangle_{0\bar{N}+1} \langle \Phi_{0,0}| (V' \otimes I)^\dagger. \end{aligned} \quad (14)$$

From the form of the reduced density matrix (14), we note that the reduced density matrix does not depend on both the starting site k and the total length of the chain N . The same property for $SU(2)S = 1$ VBS state has already been proved in [34]. We can regard above result as an $SU(n)$ generalization of their result.

Since the reduced density matrix is independent of both k and N , we can set $N = L$ without loss of generality. We can further reduce the original problem to that of the reduced density matrix of two end spins (\square and $\bar{\square}$) using the following property of a bipartite pure state. Suppose that $|\Psi\rangle_{AB}$ is a bipartite pure state of a total system AB . Then there exist orthonormal states $|\psi_j\rangle_A$ for the subsystem A , and orthonormal states $|\phi_j\rangle_B$ for B such that

$$|\Psi\rangle_{AB} = \sum_j \sqrt{p_j} |\psi_j\rangle_A |\phi_j\rangle_B, \quad (15)$$

where $p_j (>0)$ satisfy $\sum_j p_j = 1$. This decomposition is called the Schmidt decomposition. The proof of the above theorem using the singular value decomposition can be found in [45]. From equation (15), one can immediately note that the set of eigenvalues of $\rho_A = \text{Tr}_B |\Psi\rangle_{AB} \langle \Psi|$ coincides with that of $\rho_B = \text{Tr}_A |\Psi\rangle_{AB} \langle \Psi|$.

Now we can reduce the eigenvalue problem of ρ_L to that of the reduced density matrix for end two spins $\rho_{\hat{L}}$. $\rho_{\hat{L}}$ has the following form:

$$\rho_{\hat{L}} = \frac{1}{(n^2 - 1)^L} \sum_{\substack{(l_1, m_1) \\ \neq (0,0)}} \cdots \sum_{\substack{(l_L, m_L) \\ \neq (0,0)}} (U \otimes I) |\Phi_{0,0}\rangle_{0, \bar{L}+1} \langle \Phi_{0,0}| (U \otimes I)^\dagger, \quad (16)$$

where $U = U_{l_1, m_1} \cdots U_{l_L, m_L}$. To evaluate the eigenvalues of $\rho_{\hat{L}}$, it is convenient to formulate the action of $(U_{l, m} \otimes I)$ as a transfer matrix. Let us first see the action of $(U_{l', m'} \otimes I)$ on a state $|\Phi_{l, m}\rangle$,

$$(U_{l', m'} \otimes I) |\Phi_{l, m}\rangle = (X^{l'} Z^{m'} X^l Z^m \otimes I) |\Phi_{0,0}\rangle = \omega^{m'l} |\Phi_{l+l', m+m'}\rangle, \quad (17)$$

where we have used the relation $ZX = \omega XZ$. Using the above relation, we can prove that

$$(U_{l', m'} \otimes I) |\Phi_{l, m}\rangle \langle \Phi_{l, m}| (U_{l', m'} \otimes I)^\dagger = |\Phi_{l+l', m+m'}\rangle \langle \Phi_{l+l', m+m'}|. \quad (18)$$

Next, we assign the vector $(0, \dots, 0, 1((l, m)\text{th entry}), 0, \dots, 0)^t$ to the state $|\Phi_{l, m}\rangle \langle \Phi_{l, m}|$. This one-to-one correspondence plays an essential role in our analysis. From this bijection, the operation $\sum_{(l', m') \neq (0,0)} (U_{l', m'} \otimes I) |\Phi_{l, m}\rangle \langle \Phi_{l, m}| (U_{l', m'} \otimes I)^\dagger$ can be written in terms of $(n^2 \times n^2)$ -dimensional matrix as

$$T \equiv \begin{matrix} \longleftarrow & n^2 & \longrightarrow \\ \begin{pmatrix} 0 & 1 & 1 & \cdots & 1 \\ 1 & 0 & 1 & \cdots & 1 \\ 1 & 1 & 0 & \cdots & 1 \\ \vdots & \vdots & \vdots & \ddots & \vdots \\ 1 & 1 & 1 & \cdots & 0 \end{pmatrix} \end{matrix}. \quad (19)$$

This transfer matrix can be diagonalized by the following unitary matrix:

$$U_c = \frac{1}{n} \begin{pmatrix} 1 & 1 & 1 & \cdots & 1 \\ 1 & \zeta & \zeta^2 & \cdots & \zeta^{n^2-1} \\ 1 & \zeta^2 & \zeta^4 & \cdots & \zeta^{2(n^2-1)} \\ \vdots & \vdots & \vdots & \ddots & \vdots \\ 1 & \zeta^{n^2-1} & \zeta^{2(n^2-1)} & \cdots & \zeta^{(n^2-1)^2} \end{pmatrix}, \quad (20)$$

where $\zeta = \exp(2\pi i/n^2)$. Then we can obtain the explicit form of the reduced density matrix $\rho_{\hat{L}}$ as

$$\begin{aligned} \rho_{\hat{L}} &= \frac{1}{(n^2 - 1)^L} T^L(1, 0, \dots, 0)^t \\ &= \frac{1}{(n^2 - 1)^L} U_c [\text{diag}(n^2 - 1, -1, \dots, -1)]^L U_c^\dagger(1, 0, \dots, 0)^t \\ &= \frac{1}{n^2} (1 + (n^2 - 1)p_n(L)) |\Phi_{0,0}\rangle_{0N+1} \langle \Phi_{0,0}| \\ &\quad + \frac{1}{n^2} \sum_{(l,m) \neq (0,0)} (1 - p_n(L)) |\Phi_{l,m}\rangle_{0N+1} \langle \Phi_{l,m}|, \end{aligned} \tag{21}$$

where we have used the relation, $1 + \zeta^k + \zeta^{2k} + \dots + \zeta^{(n^2-1)k} = 0$ ($1 \leq k \leq n^2 - 1$) and $p_n(L) = \left(\frac{-1}{n^2-1}\right)^L$. Substituting $n = 2$ into equation (21), one can reproduce the result of the $SU(2)S = 1$ VBS state obtained in [34].

Let us now start the evaluation of the von Neumann and the Rényi entropies of a block of L contiguous spins. First, we shall examine the von Neumann entropy of the block. From the Schmidt decomposition and the definition of the von Neumann entropy $S(\rho_L) = S(\rho_{\hat{L}}) = -\text{Tr}_{0,\overline{L+1}}(\rho_{\hat{L}} \log \rho_{\hat{L}})$, we obtain

$$\begin{aligned} S(\rho_L) &= 2 \log n - \frac{1 + (n^2 - 1)p_n(L)}{n^2} \log(1 + (n^2 - 1)p_n(L)) \\ &\quad - (n^2 - 1) \frac{1 - p_n(L)}{n^2} \log(1 - p_n(L)) \end{aligned} \tag{22}$$

with $p_n(L) = \left(\frac{-1}{n^2-1}\right)^L$. Similarly to the $SU(2)$ integer- S VBS states [34, 35, 36] and the XY spin chains in the gapped regime [6, 39–41], $S(\rho_L)$ is bounded by $2 \log n$ in the limit of large block sizes ($L \rightarrow \infty$) and approaches to this value exponentially fast in L . This is a partial proof of the conjecture proposed by Vidal *et al* [3], that the von Neumann entropy of a large block of spins in gapped spin chains shows saturation. Next we shall examine the Rényi entropy of our system. From the definition of the Rényi entropy $S_\alpha(\rho_L) = \frac{1}{1-\alpha} \log \text{Tr}(\rho_L^\alpha)$ ($\alpha \neq 1, \text{ and } \alpha > 0$),

$$S_\alpha(\rho_L) = \frac{1}{1-\alpha} \log(\lambda_{0,0}(L)^\alpha + (n^2 - 1)\lambda_{l,m \neq 0,0}(L)^\alpha), \tag{23}$$

where

$$\lambda_{l,m}(L) = \begin{cases} \frac{1}{n^2} (1 + (n^2 - 1)p_n(L)), & (l, m) = (0, 0) \\ \frac{1}{n^2} (1 - p_n(L)) & (l, m) \neq (0, 0). \end{cases} \tag{24}$$

Now we consider the limit of large block sizes, i.e., $L \rightarrow \infty$. In this case, $\lambda_{l,m}$ become degenerate and great simplification occurs

$$\begin{aligned} S_\alpha(\rho_L) &= \frac{1}{1-\alpha} \log \left(\left(\frac{1}{n^2}\right)^\alpha + (n^2 - 1) \left(\frac{1}{n^2}\right)^\alpha \right) \\ &= \frac{1}{1-\alpha} \log(n^2)^{1-\alpha} \\ &= 2 \log n. \end{aligned} \tag{25}$$

Now we note that the Rényi entropy is independent of α and furthermore coincides with the von Neumann entropy. This means that the reduced density matrix of a large block is proportional

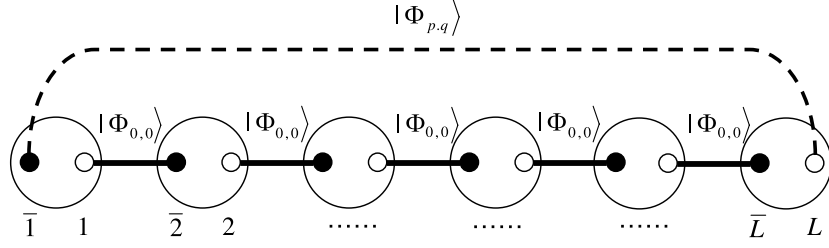

Figure 2. Construction of the edge state $|p, q\rangle$ in an open boundary spin chain. A white (black) dot represents the $SU(n)$ fundamental (conjugate) representation. A circle denotes the projection onto the adjoint representation. The dotted line corresponds to the state $|\Phi_{p,q}\rangle$.

to n^2 -dimensional identity matrix. In other words, a sufficiently large block of neighboring spins has n^2 effective degrees of freedom and in this reduced subspace, the block is maximally entangled with the rest of the chain. Finally we consider the analytic property of the Rényi entropy on the complex α -plane. In the large block limit, $S_\alpha(\rho_\infty)$ is independent of α and hence S_α is completely analytic on α -plane. On the other hand, if we consider the finite-size block, $S_\alpha(\rho_L)$ has branch cuts starting from α_{bc} . The branch points α_{bc} are determined from the condition $\lambda_{0,0}(L)^\alpha + (n^2 - 1)\lambda_{l,m \neq 0,0}(L)^\alpha = 0$. The explicit value of α_{bc} is given by

$$\alpha_{bc} = \frac{(2m + 1)\pi i + \log(n^2 - 1)}{\log(\lambda_{0,0}(L)/\lambda_{l,m \neq 0,0}(L))} \quad (26)$$

with $m \in \mathbf{Z}$. Since all the eigenvalues $\lambda_{l,m}$ become degenerate in the limit of large block sizes, the denominator of equation (26) becomes zero and hence α_{bc} converge to the point at infinity. This is the reason why the Rényi entropy in this limit is completely analytic on the complex α -plane. We also find the novel even–odd alternation of the real part of α_{bc} , i.e., $\text{Re}[\alpha_{bc}] > 0$ for even L , while $\text{Re}[\alpha_{bc}] < 0$ for odd L .

2.3. Reduced density matrix as a projector onto the subspace of edge states

As we have seen in the previous subsection, the von Neumann and Rényi entropies are obtained from the reduced density matrix for end two spins ($\rho_{\bar{l}}$). The number of degrees of freedom in the subsystem can be counted from the von Neumann entropy as n^2 . This number coincides with the number of edge states which are degenerate ground states of the AKLT model with an open boundary condition. In the case of $SU(2)$ AKLT model, the close relation between the von Neumann entropy and the number of edge states has been extensively discussed [35, 47]. In this subsection, we elucidate the direct relation between the reduced density matrix (14) and the edge states. First, we consider the open boundary $SU(n)$ AKLT model with L sites. The Hamiltonian is given by $H_{\text{open}} = \sum_{k=1}^{L-1} H_k$. The only difference from equation (6) is that there are no boundary terms. The basis of the edge states is constructed as

$$|p, q\rangle \equiv C_{p,q} \sum_{\substack{(l_1, m_1) \\ \neq (0,0)}} \cdots \sum_{\substack{(l_L, m_L) \\ \neq (0,0)}} |\Phi_{l_1, -m_1}\rangle_{\bar{1}1} \cdots |\Phi_{l_{L-1}, -m_{L-1}}\rangle_{\bar{L-1}L-1} \\ \times P_{L\bar{L}}((U_{p,q} U_{l_1, m_1} \cdots U_{l_{L-1}, m_{L-1}} \otimes I) |\Phi_{0,0}\rangle_{L\bar{L}}), \quad (27)$$

where $C_{p,q}$ is a normalization factor. Any linear combination of (27) is apparently the ground state of H_{open} . The graphical representation of the construction of this state is shown in figure 2. The following orthogonality relation of edge state holds: $\langle p, q|r, s\rangle =$

$C_{p,q}^2 (n^2 - 1)^L \delta_{p,r} \delta_{q,s} \lambda_{-p,-q}(L)$ (the subscripts $-p$ and $-q$ are modulo n). This can be shown as follows:

$$\begin{aligned}
 \langle p, q | r, s \rangle &= C_{p,q} C_{r,s} \sum_{\substack{(l_1, m_1) \\ \neq (0,0)}} \cdots \sum_{\substack{(l_{L-1}, m_{L-1}) \\ \neq (0,0)}} {}_{L\bar{L}} \langle \Phi_{0,0} | (U_{p,q} U_{l_1, m_1} \cdots U_{l_{L-1}, m_{L-1}} \otimes I)^\dagger \\
 &\quad \times P_{L\bar{L}} (U_{r,s} U_{l_1, m_1} \cdots U_{l_{L-1}, m_{L-1}} \otimes I) | \Phi_{0,0} \rangle_{L\bar{L}} \\
 &= C_{p,q} C_{r,s} \sum_{\substack{(l, m) \\ \neq (0,0)}} \sum_{\substack{(l_1, m_1) \\ \neq (0,0)}} \cdots \sum_{\substack{(l_{L-1}, m_{L-1}) \\ \neq (0,0)}} {}_{L\bar{L}} \langle \Phi_{0,0} | (U_{l_1, m_1} \cdots U_{l_{L-1}, m_{L-1}} \otimes I)^\dagger \\
 &\quad \times (U_{p,q} \otimes I)^\dagger | \Phi_{l, m} \rangle_{L\bar{L}} \langle \Phi_{l, m} | (U_{r,s} \otimes I) (U_{l_1, m_1} \cdots U_{l_{L-1}, m_{L-1}} \otimes I) | \Phi_{0,0} \rangle_{L\bar{L}} \\
 &= C_{p,q} C_{r,s} (n^2 - 1)^{L-1} \sum_{(l', m')} \lambda_{l', m'} (L - 1) \\
 &\quad \times {}_{L\bar{L}} \langle \Phi_{p+l', q+m'} | (1 - |\Phi_{0,0}\rangle_{L\bar{L}} \langle \Phi_{0,0}|) | \Phi_{r+l', s+m'} \rangle_{L\bar{L}} \\
 &= C_{p,q}^2 (n^2 - 1)^L \delta_{p,r} \delta_{q,s} \lambda_{-p,-q}(L). \tag{28}
 \end{aligned}$$

Here we have recalled equation (16) and have used the relation

$$\begin{aligned}
 \sum_{\substack{(l_1, m_1) \\ \neq (0,0)}} \cdots \sum_{\substack{(l_{L-1}, m_{L-1}) \\ \neq (0,0)}} (U_{l_1, m_1} \cdots U_{l_{L-1}, m_{L-1}} \otimes I) | \Phi_{0,0} \rangle_{L\bar{L}} \langle \Phi_{0,0} | (U_{l_1, m_1} \cdots U_{l_{L-1}, m_{L-1}} \otimes I)^\dagger \\
 = (n^2 - 1)^{L-1} \rho_{L-1} = (n^2 - 1)^{L-1} \sum_{(l, m)} \lambda_{l, m} (L - 1) | \Phi_{l, m} \rangle_{L\bar{L}} \langle \Phi_{l, m} |. \tag{29}
 \end{aligned}$$

The explicit form of the normalization factors $C_{p,q}$ are given by $C_{p,q} = 1/\sqrt{(n^2 - 1)^L \lambda_{-p,-q}(L)}$. Next, we try to write ρ_L in terms of the basis of edge states. By the original definition,

$$\begin{aligned}
 \rho_L &= \text{Tr}_{0, \bar{L}+1} |G\rangle \langle G| \\
 &= \frac{1}{(n^2 - 1)^L} \sum_{(p,q)} \sum_{\substack{(l_1, m_1) \\ \neq (0,0)}} \sum_{\substack{(l'_1, m'_1) \\ \neq (0,0)}} \cdots \sum_{\substack{(l_{L-1}, m_{L-1}) \\ \neq (0,0)}} \sum_{\substack{(l'_{L-1}, m'_{L-1}) \\ \neq (0,0)}} \\
 &\quad \times | \Phi_{l_1, -m_1} \rangle \langle \Phi_{l'_1, -m'_1} | \cdots | \Phi_{l_{L-1}, -m_{L-1}} \rangle \langle \Phi_{l'_{L-1}, -m'_{L-1}} | \\
 &\quad \times P_{L\bar{L}} (U_{p,q} U_{l_1, m_1} \cdots U_{l_{L-1}, m_{L-1}} \otimes I) | \Phi_{0,0} \rangle_{L\bar{L}} \\
 &\quad \times \langle \Phi_{0,0} | (U_{p,q} U_{l'_1, m'_1} \cdots U_{l'_{L-1}, m'_{L-1}} \otimes I)^\dagger P_{L\bar{L}}. \tag{30}
 \end{aligned}$$

Then comparing with equation (27), we obtain

$$\rho_L = \sum_{(p,q)} \lambda_{-p,-q}(L) |p, q\rangle \langle p, q|, \tag{31}$$

where $\lambda_{-p,-q}(= \lambda_{n-p, n-q})$ was defined in equation (24). Therefore we conclude that the reduced density matrix of a block of contiguous spins in the ground state is completely characterized by the ground states of corresponding open spin chain. In the limit of large block sizes, i.e., $L \rightarrow \infty$, ρ_L can be written as

$$\rho_L = \frac{1}{n^2} \sum_{(p,q)} |p, q\rangle \langle p, q|. \tag{32}$$

In this limit, the limiting density matrix can be regarded as a projector which projects on a subspace spanned by the degenerate ground states for open boundary AKLT model.

3. The periodic $SU(n)$ VBS state

In this section, we shall focus on the von Neumann and the Rényi entropies of the periodic $SU(n)$ VBS state. The periodic VBS state with length N can be constructed by acting the projection operator on the edges of the VBS state with boundary spins. We use the following representation for the ground state:

$$\begin{aligned}
 |G_p\rangle &= \frac{1}{\mathcal{N}} \sum_{\substack{(l_1, m_1) \\ \neq (0,0)}} \cdots \sum_{\substack{(l_{L-1}, m_{L-1}) \\ \neq (0,0)}} \sum_{\substack{(l_{L+1}, m_{L+1}) \\ \neq (0,0)}} \cdots \sum_{\substack{(l_N, m_N) \\ \neq (0,0)}} \\
 &\times |\Phi_{l_1, -m_1}\rangle_{\bar{1}1} \cdots |\Phi_{l_{L-1}, -m_{L-1}}\rangle_{\bar{L-1}L-1} |\Phi_{l_{L+1}, -m_{L+1}}\rangle_{\bar{L+1}L+1} \cdots |\Phi_{l_N, -m_N}\rangle_{\bar{N}N} \\
 &\times P_{L\bar{L}}(U_{l_{L+1}, m_{L+1}} \cdots U_{l_N, m_N} U_{l_1, m_1} \cdots U_{l_{L-1}, m_{L-1}} \otimes I) |\Phi_{0,0}\rangle_{L\bar{L}}, \tag{33}
 \end{aligned}$$

where $\mathcal{N}^2 = (n^2 - 1)^N (1 + (n^2 - 1)p_n(N))/n^2$ is a normalization factor. In the above state, the L th site consists of the left (\square) and right ($\bar{\square}$) ‘spins’ in the original open $SU(n)$ VBS state. The reduced density matrix of a block of contiguous spins with length L is given by

$$\begin{aligned}
 \rho_{N,L} &= \text{Tr}_{L+1 \dots N} |G_p\rangle \langle G_p| \\
 &= \frac{1}{\mathcal{N}^2} \sum_{\substack{(l_1, m_1) \\ \neq (0,0)}} \sum_{\substack{(l'_1, m'_1) \\ \neq (0,0)}} \cdots \sum_{\substack{(l_{L-1}, m_{L-1}) \\ \neq (0,0)}} \sum_{\substack{(l'_{L-1}, m'_{L-1}) \\ \neq (0,0)}} \sum_{\substack{(l_{L+1}, m_{L+1}) \\ \neq (0,0)}} \cdots \sum_{\substack{(l_N, m_N) \\ \neq (0,0)}} \\
 &\times |\Phi_{l_1, -m_1}\rangle_{\bar{1}1} \langle \Phi_{l'_1, -m'_1}| \cdots |\Phi_{l_{L-1}, -m_{L-1}}\rangle_{\bar{L-1}L-1} \langle \Phi_{l'_{L-1}, -m'_{L-1}}| \\
 &\times P_{L\bar{L}}(V_1 U_3 \otimes I) |\Phi_{0,0}\rangle_{L\bar{L}} \langle \Phi_{0,0}| (V'_1 U_3 \otimes I)^\dagger P_{L\bar{L}}, \tag{34}
 \end{aligned}$$

where $V_1 = U_{l_1, m_1} \cdots U_{l_{L-1}, m_{L-1}}$, $V'_1 = U_{l'_1, m'_1} \cdots U_{l'_{L-1}, m'_{L-1}}$ and $U_3 = U_{l_{L+1}, m_{L+1}} \cdots U_{l_N, m_N}$. Here it is convenient to introduce the following density matrix:

$$\begin{aligned}
 \rho_{\widehat{N-L}} &= \frac{1}{(n^2 - 1)^{N-L}} \sum_{\substack{(l_{L+1}, m_{L+1}) \\ \neq (0,0)}} \cdots \sum_{\substack{(l_N, m_N) \\ \neq (0,0)}} (U_3 \otimes I) |\Phi_{0,0}\rangle_{L\bar{L}} \langle \Phi_{0,0}| (U_3 \otimes I)^\dagger \\
 &= \sum_{(l,m)} \lambda_{l,m} (N - L) |\Phi_{l,m}\rangle_{L\bar{L}} \langle \Phi_{l,m}|. \tag{35}
 \end{aligned}$$

The above expression is obtained from equation (16) by replacing L with $N - L$. Equation (34) can be written in terms of $\rho_{\widehat{N-L}}$ as

$$\begin{aligned}
 \rho_{N,L} &= \frac{1}{\mathcal{N}^2} (n^2 - 1)^{N-L} \sum_{\substack{(l_1, m_1) \\ \neq (0,0)}} \sum_{\substack{(l'_1, m'_1) \\ \neq (0,0)}} \cdots \sum_{\substack{(l_{L-1}, m_{L-1}) \\ \neq (0,0)}} \sum_{\substack{(l'_{L-1}, m'_{L-1}) \\ \neq (0,0)}} |\Phi_{l_1, -m_1}\rangle_{\bar{1}1} \langle \Phi_{l'_1, -m'_1}| \\
 &\times \cdots |\Phi_{l_{L-1}, -m_{L-1}}\rangle_{\bar{L-1}L-1} \langle \Phi_{l'_{L-1}, -m'_{L-1}}| P_{L\bar{L}}(V_1 \otimes I) \rho_{\widehat{N-L}}(V'_1 \otimes I)^\dagger P_{L\bar{L}}, \\
 &= \frac{1}{\mathcal{N}^2} (n^2 - 1)^{N-L} \sum_{(l,m)} \lambda_{l,m} (N - L) \sum_{\substack{(l_1, m_1) \\ \neq (0,0)}} \sum_{\substack{(l'_1, m'_1) \\ \neq (0,0)}} \\
 &\times \cdots \sum_{\substack{(l_{L-1}, m_{L-1}) \\ \neq (0,0)}} \sum_{\substack{(l'_{L-1}, m'_{L-1}) \\ \neq (0,0)}} |\Phi_{l_1, -m_1}\rangle_{\bar{1}1} \langle \Phi_{l'_1, -m'_1}| \cdots |\Phi_{l_{L-1}, -m_{L-1}}\rangle_{\bar{L-1}L-1} \\
 &\times \langle \Phi_{l'_{L-1}, -m'_{L-1}}| P_{L\bar{L}}(V_1 \otimes I) |\Phi_{l,m}\rangle_{L\bar{L}} \langle \Phi_{l,m}| (V'_1 \otimes I)^\dagger P_{L\bar{L}}. \tag{36}
 \end{aligned}$$

Here we recall the basis of edge states (27) and obtain

$$\begin{aligned}\rho_{N,L} &= \frac{1}{\mathcal{N}^2} (n^2 - 1)^{N-L} \sum_{(l,m)} \frac{\lambda_{l,m}(N-L)}{C_{l,m}^2} |l, m\rangle \langle l, m|, \\ &= \sum_{(l,m)} \lambda_{l,m}(N, L) |l, m\rangle \langle l, m|,\end{aligned}\quad (37)$$

where $\lambda_{l,m}(N, L) = \frac{\lambda_{l,m}(N-L)}{\mathcal{N}^2 C_{l,m}^2} (n^2 - 1)^{N-L}$ are eigenvalues of the reduced density matrix. They are explicitly given by

$$\lambda_{l,m}(N, L) = \begin{cases} \frac{1}{n^2} \frac{(1 + (n^2 - 1)p_n(N-L))(1 + (n^2 - 1)p_n(L))}{(1 + (n^2 - 1)p_n(N))} & (l, m) = (0, 0) \\ \frac{1}{n^2} \frac{(1 - p_n(N-L))(1 - p_n(L))}{(1 + (n^2 - 1)p_n(N))} & (l, m) \neq (0, 0). \end{cases}\quad (38)$$

Putting $n = 2$ into equation (38) reproduces the results of $S = 1$ case obtained in [47].

Now we know the reduced density matrix of a block with arbitrary system size N , subsystem size L and internal degrees of freedom n , we can study the finite-size effect on entanglement properties. In the limit of $N \rightarrow \infty$, the set of eigenvalues of the density matrix $\rho_{N,L}$ becomes equivalent to that of the VBS state with boundary spins, and hence the entanglement properties are identical to each other. The explicit form of the entanglement is similar to that in the previous section. The von Neumann and the Rényi entropies for periodic case are written as

$$\begin{aligned}S(\rho_{N,L}) &= -\lambda_{0,0}(N, L) \log \lambda_{0,0}(N, L) - (n^2 - 1) \lambda_{l,m \neq 0,0}(N, L) \log \lambda_{l,m \neq 0,0}(N, L), \\ S_\alpha(\rho_{N,L}) &= \frac{1}{1 - \alpha} \log(\lambda_{0,0}(N, L) + (n^2 - 1) \lambda_{l,m \neq 0,0}(N, L)).\end{aligned}\quad (39)$$

Similarly to the previous section, both $S(\rho_{N,L})$ and $S_\alpha(\rho_{N,L})$ approach $2 \log n$ in the thermodynamic limit. Here what we mean by *thermodynamic limit* is the limit in which $N \rightarrow \infty$, $L \rightarrow \infty$ with a parameter L/N fixed at some value.

As we saw in the calculation of the reduced density matrix, we found non-trivial consequence that the reduced density matrix is completely written in terms of the edge states of the open boundary AKLT model which corresponds to the Hamiltonian describing the subsystem ripped off by tracing out. It clarifies the edge state interpretation of the entanglement entropy, which is also discussed in several papers [35, 36, 46, 47], in more detail. We can see the separation of the eigenvalues of the reduced density matrix, i.e., $\lambda_{0,0}(N, L) \neq \lambda_{l,m \neq 0,0}(N, L)$ in finite-size systems. Here we shall explain the physical meaning of this separation. This is due to the qualitative difference between the singlet state $|0, 0\rangle$ and the adjoint states $|l, m\rangle$, $(l, m) \neq (0, 0)$ induced by the effective coupling of residual edge ‘spins’ on the boundaries of the subsystem. In the thermodynamic limit, the reduced density matrix is proportional to the identity matrix, which indicates the absence of the effective coupling in this limit and hence the edge spins behave freely without interaction. Therefore, the von Neumann entropy is proportional to the logarithm of the number of degrees of freedom due to the residual edge spins.

4. Summary and discussions

We analyzed entanglement in the ground state of the $SU(n)$ version of AKLT model. We consider a block of spins in the ground state, it is in the mixed state. We evaluated the von Neumann entropy and the Rényi entropy of the block. We first examined the VBS ground

state with boundary spins. We found that the great simplification occurs in the limit of large block sizes. In this case, the Rényi entropy is independent of the parameter α and furthermore it coincides with the value of von Neumann entropy $2 \ln n$. This means that the density matrix of the block is proportional to identical matrix of dimension n^2 . We clarified that subspace of eigenvectors of the density matrix with nonzero eigenvalues describes the degenerate ground states of the block, i.e., edge states. We studied the finite-size effect on the Rényi entropy in terms of analyticity on the complex α -plane. Then we studied the periodic VBS state. In this case, we also obtained the exact expression for the reduced density matrix and found the essential simplification in the thermodynamic limit.

Acknowledgments

The authors are grateful to S Murakami, and Y Hatsugai for fruitful discussions. This work was supported in part by NSF grant DMS-0503712 (VEK), Grant-in-Aids (grant nos 15104006, 16076205 and 17105002) and NAREGI Nanoscience Project from the Ministry of Education, Culture, Sports, Science and Technology. HK was supported by the Japan Society for the Promotion of Science.

References

- [1] Osterloh A, Amico L, Falci G and Fazio R 2002 *Nature (London)* **416** 608 (Preprint [quant-ph/0202029](#))
- [2] Osborne T J and Nielsen M A 2002 *Phys. Rev. A* **66** 032110 (Preprint [quant-ph/0202162](#))
- [3] Vidal G, Latorre J I, Rico E and Kitaev A 2003 *Phys. Rev. Lett.* **90** 227902 (Preprint [quant-ph/0211074](#))
- [4] Latorre J I, Rico E and Vidal G 2004 *Quantum Inf. Comput.* **4** 048 (Preprint [quant-ph/0304098](#))
- [5] Jin B-Q and Korepin V E 2004 *J. Stat. Phys.* **116** 79 (Preprint [quant-ph/0304108](#))
- [6] Its A R, Jin B-Q and Korepin V E 2005 *J. Phys. A: Math. Gen.* **38** 2975 (Preprint [quant-ph/0409027](#))
- [7] Arnesen M C, Bose S and Vedral V 2001 *Phys. Rev. Lett.* **87** 017901 (Preprint [quant-ph/0009060](#))
- [8] Verstraete F, Martín-Delgado M A and Cirac J I 2004 *Phys. Rev. Lett.* **92** 087201 (Preprint [quant-ph/0311087](#))
- [9] Pachos J K and Plenio M B 2004 *Phys. Rev. Lett.* **93** 056402 (Preprint [quant-ph/0401106](#))
- [10] Fan H and Lloyd S 2005 *J. Phys. A: Math. Gen.* **38** 5285 (Preprint [quant-ph/0405130](#))
- [11] Vedral V 2004 *New J. Phys.* **6** 102 (Preprint [quant-ph/0405102](#))
- [12] Chen Y, Zanardi P, Wang Z D and Zhang F C 2006 *New J. Phys.* **8** 97 (Preprint [quant-ph/0407228](#))
- [13] Hamma A, Ionicioiu R and Zanardi P 2005 *Phys. Lett. A* **337** 22 (Preprint [quant-ph/0406202](#))
- [14] Popkov V and Salerno M 2005 *Phys. Rev. A* **71** 012301 (Preprint [quant-ph/0404026](#))
- [15] Keating J P and Mezzadri F 2004 *Commun. Math. Phys.* **252** 543 (Preprint [quant-ph/0407047](#))
- [16] Gu S-J, Deng S-S, Li Y-Q and Lin H-Q 2004 *Phys. Rev. Lett.* **93** 086402 (Preprint [quant-ph/0405067](#))
- [17] Gu S-J, Lin H-Q and Li Y-Q 2003 *Phys. Rev. A* **68** 042330 (Preprint [quant-ph/0307131](#))
- [18] Wang J and Kais S 2004 *Phys. Rev. A* **70** 022301 (Preprint [quant-ph/0405087](#))
- [19] Korepin V E 2004 *Phys. Rev. Lett.* **92** 096402 (Preprint [cond-mat/0311056](#))
- [20] Audenaert K, Eisert J, Plenio M B and Werner R F 2002 *Phys. Rev. A* **66** 042327 (Preprint [quant-ph/0205025](#))
- [21] Bennett C H and DiVincenzo D P 2000 *Nature* **404** 247
- [22] Lloyd S 1993 *Science* **261** 1569
Lloyd S 1994 *Science* **263** 695
- [23] Levin M and Wen X G 2006 *Phys. Rev. Lett.* **96** 110405 (Preprint [cond-mat/0510613](#))
- [24] Kitaev A and Preskill J 2006 *Phys. Rev. Lett.* **96** 110404 (Preprint [hep-th/0510092](#))
- [25] Rényi A 1970 *Probability Theory* (Amsterdam: North-Holland)
- [26] Affleck A, Kennedy T, Lieb E H and Tasaki H 1988 *Commun. Math. Phys.* **115** 477
- [27] Affleck A, Kennedy T, Lieb E H and Tasaki H 1987 *Phys. Rev. Lett.* **59** 799
- [28] Haldane F D M 1983 *Phys. Lett. A* **93** 464
Haldane F D M 1983 *Phys. Rev. Lett.* **50** 1153
- [29] Kirillov A N and Korepin V E 1990 *Algebra and analysis St. Petersburg Math. J.* **1** 47
- [30] Garcia-Ripoll J J, Martín-Delgado M A and Cirac J I 2004 *Phys. Rev. Lett.* **93** 250405 (Preprint [cond-mat/0404566](#))
- [31] Verstraete F and Cirac J I 2004 *Phys. Rev. A* **70** 060302(R) (Preprint [quant-ph/0311130](#))

- [32] Laughlin R B 1983 *Phys. Rev. Lett.* **50** 1395
- [33] Arovas D P, Auerbach A and Haldane F D M 1988 *Phys. Rev. Lett.* **60** 531
- [34] Fan H, Korepin V and Roychowdhury V 2004 *Phys. Rev. Lett.* **93** 227203 (*Preprint quant-ph/0406067*)
- [35] Katsura H, Hirano T and Hatsugai Y 2007 *Phys. Rev. B* **76** 012401 (*Preprint cond-mat/0702196*)
- [36] Xu Y, Katsura H, Hirano T and Korepin V E 2008 *Preprint arXiv: 0802.3221*
- [37] Greiter M, Rachel S and Schuricht D 2007 *Phys. Rev.* **75** 060401(R) (*Preprint cond-mat/0701354*)
- [38] Greiter M and Rachel S 2007 *Phys. Rev. B* **75** 184441 (*Preprint cond-mat/0702443*)
- [39] Its A R, Jin B-Q and Korepin V E 2006 (*Preprint quant-ph/0606178*)
- [40] Franchini F, Its A R, Jin B-Q and Korepin V E 2006 (*Preprint quant-ph/0606240*)
- [41] Franchini F, Its A R, Jin B-Q and Korepin V E 2007 *J. Phys. A: Math. Theor.* **40** 8467 (*Preprint quant-ph/0609098*)
- [42] Franchini F, Its A R and Korepin V E 2008 *J. Phys. A: Math. Theor.* **41** 025302 (*Preprint 0707.2534*)
- [43] Entanglement of $SU(n)$ singlet formed by n fundamental representations is considered in the following article:
Nussinov Z and Ortiz G 2007 (*Preprint cond-mat/0702377*)
- [44] Fan H 2004 *Phys. Rev. Lett.* **92** 177905 (*Preprint quant-ph/0311026*)
- [45] Nielsen M A and Chuang I L 2000 *Quantum Computation and Quantum Information* (Cambridge: Cambridge University Press)
- [46] Ryu S and Hatsugai Y 2006 *Phys. Rev. B* **73** 245115 (*Preprint cond-mat/0601237*)
- [47] Hirano T and Hatsugai Y 2007 *J. Phys. Soc. Japan* **76** 074603 (*Preprint cond-mat/0703642*)